

# Cd70 CKO Strategy

Designer: Xueting Zhang

Reviewer: Ruirui Zhang

Design Date: 2026-4-8

# Overview

## Target Gene Name

- Cd70

## Project Type

- CKO

## Genetic Background

- C57BL/6JGpt

# Strain Strategy

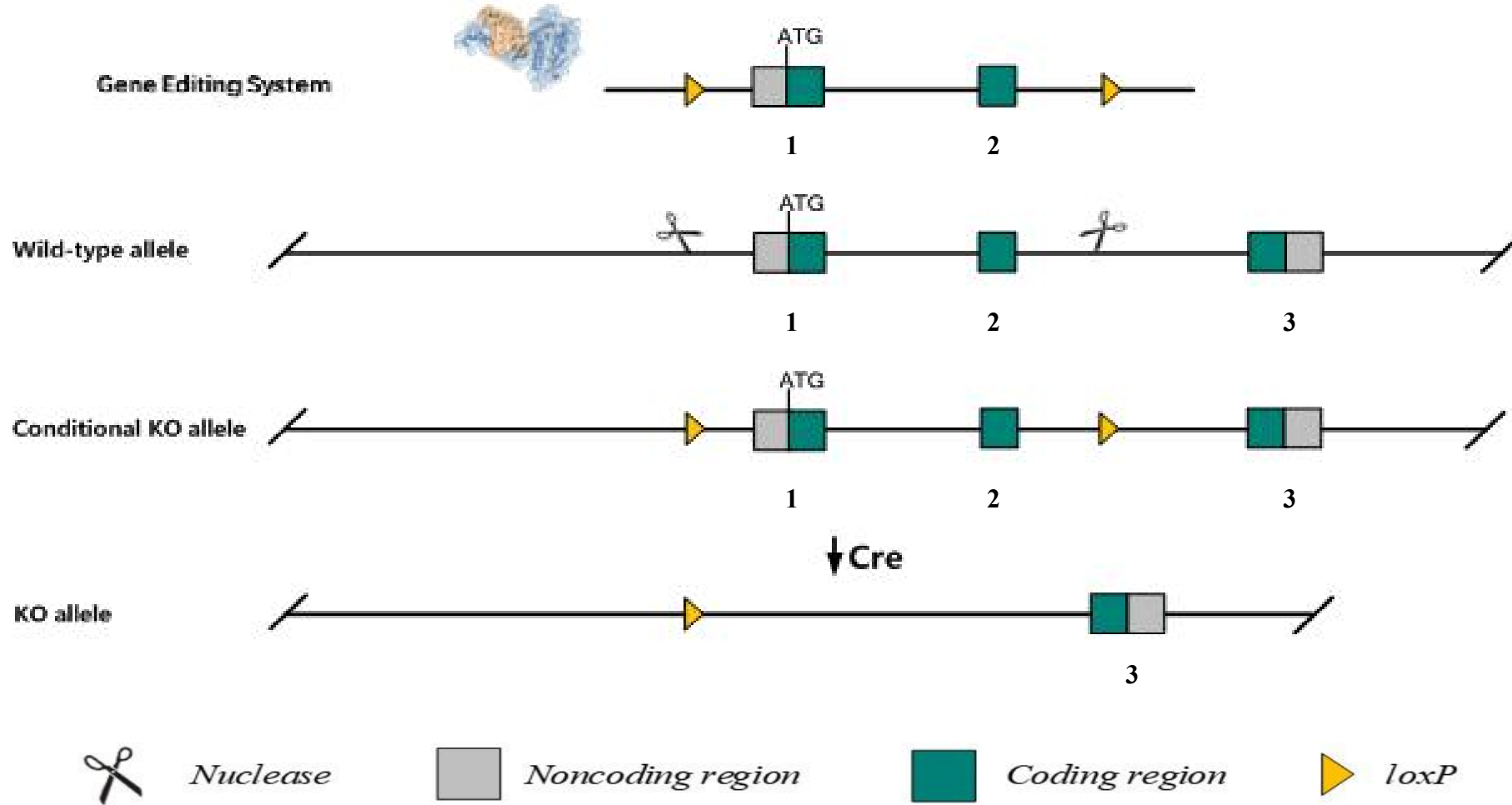

Schematic representation of nuclease system used to edit the *Cd70* gene.

# Technical Information

- The *Cd70* gene has 1 transcript. According to the structure of *Cd70* gene, exon 1-exon 2 of *Cd70*-201 (ENSMUST00000019633.8) transcript is recommended as the knockout region. The region contains start codon ATG. Knocking out the region will result in disruption of protein function.
- In this project we use gene editing technology to modify *Cd70* gene. The brief process is as follows: nuclease system and donor were constructed in vitro, and microinjected into the fertilized eggs of C57BL/6JGpt mice. Fertilized eggs were transplanted to obtain positive F0 mice which were confirmed by PCR and on-target amplicon sequencing. A stable F1-generation mouse strain was obtained by mating positive F0-generation mice with C57BL/6JGpt mice and confirmation of the desired mutant allele was carried out by PCR and on-target amplicon sequencing.
- The flox mice will be knocked out after mating with mice expressing Cre recombinase, resulting in the loss of function of the target gene in specific tissues and cell types.

# Gene Information

**Cd70** CD70 antigen [ *Mus musculus* (house mouse) ]

[Download Datasets](#)

Gene ID: 21948, updated on 4-Feb-2026

## Summary

<b>Official Symbol</b>	Cd70 provided by <a href="#">MGI</a>
<b>Official Full Name</b>	CD70 antigen provided by <a href="#">MGI</a>
<b>Primary source</b>	<a href="#">MGI:MGI:1195273</a>
<b>See related</b>	<a href="#">Ensembl:ENSMUSG00000019489</a> <a href="#">AllianceGenome:MGI:1195273</a>
<b>Gene type</b>	protein coding
<b>RefSeq status</b>	PROVISIONAL
<b>Organism</b>	<a href="#">Mus musculus</a>
<b>Lineage</b>	Eukaryota; Metazoa; Chordata; Craniata; Vertebrata; Euteleostomi; Mammalia; Eutheria; Euarchontoglires; Glires; Rodentia; Myomorpha; Muroidea; Muridae; Murinae; Mus; Mus
<b>Also known as</b>	Cd27l; CD27LG; Tnfsf7; Tnlg8a
<b>Summary</b>	Enables receptor ligand activity. Involved in T cell proliferation. Is active in plasma membrane. Is expressed in Meckel's cartilage; hip; and skeleton. Human ortholog(s) of this gene implicated in lymphoproliferative syndrome. Orthologous to human CD70 (CD70 molecule). [provided by Alliance of Genome Resources, Jul 2025]
<b>Expression</b>	Biased expression in thymus adult (RPKM 2.9), cerebellum adult (RPKM 2.7) and 5 other tissues <a href="#">See more</a>
<b>Orthologs</b>	<a href="#">all</a>

[Try the new Gene page](#)  
[Try the new Transcripts and proteins table](#)

Source: <https://www.ncbi.nlm.nih.gov/>

# Transcript Information

The gene has 1 transcript, and the transcript is shown below:

Transcript ID	Name	bp	Protein	Biotype	CCDS	UniProt Match	Flags
<a href="#">ENSMUST00000019633.8</a>	Cd70-201	842	<a href="#">195aa</a>	Protein coding	<a href="#">CCDS28927</a>	<a href="#">O55237</a> <a href="#">Q05A52</a>	Ensembl Canonical Gencode Primary Gencode Basic APPRIS P1 TSL:1

The strategy is based on the design of *Cd70-201* transcript, the transcription is shown below:

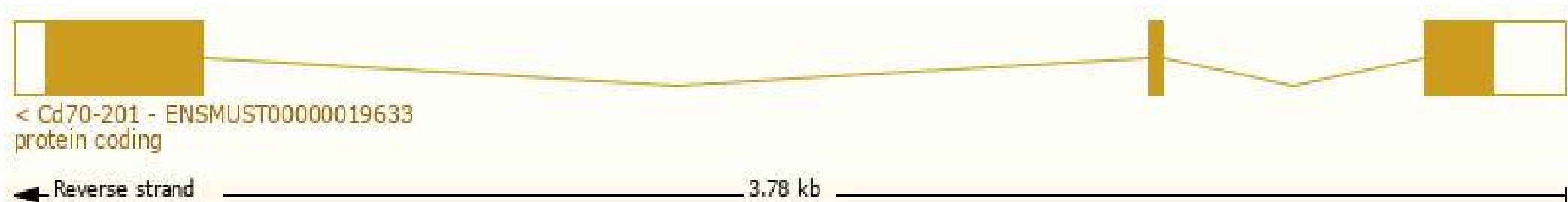

Source: <https://www.ensembl.org>

# Genomic Information

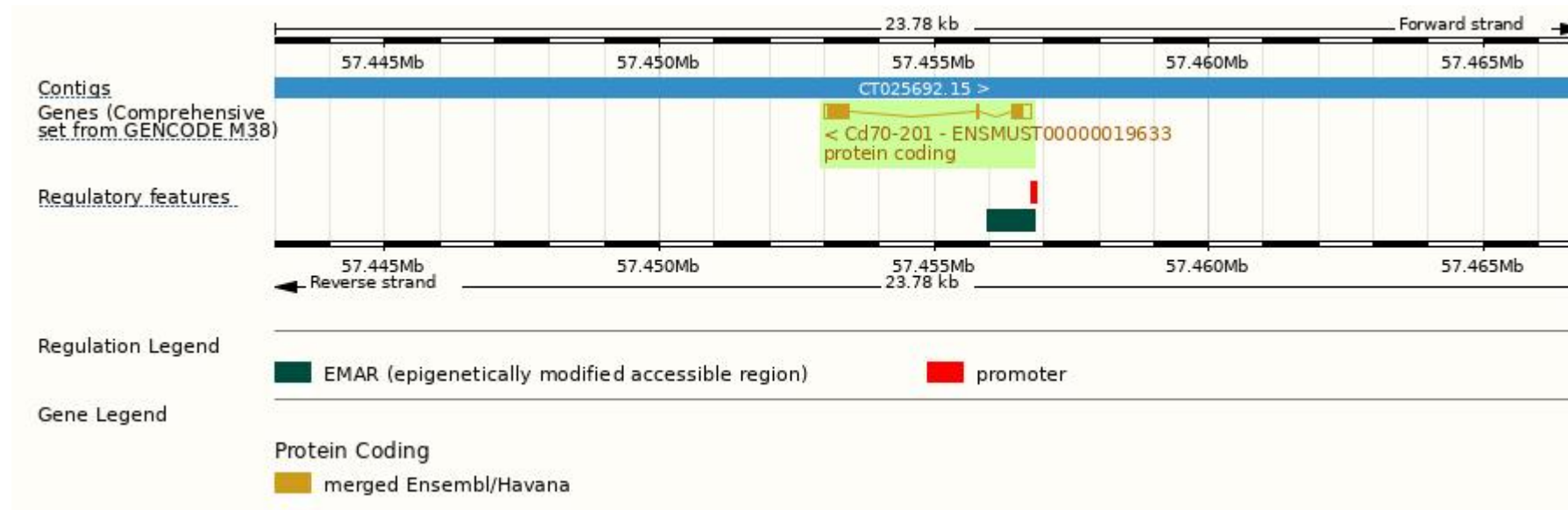

# Protein Information

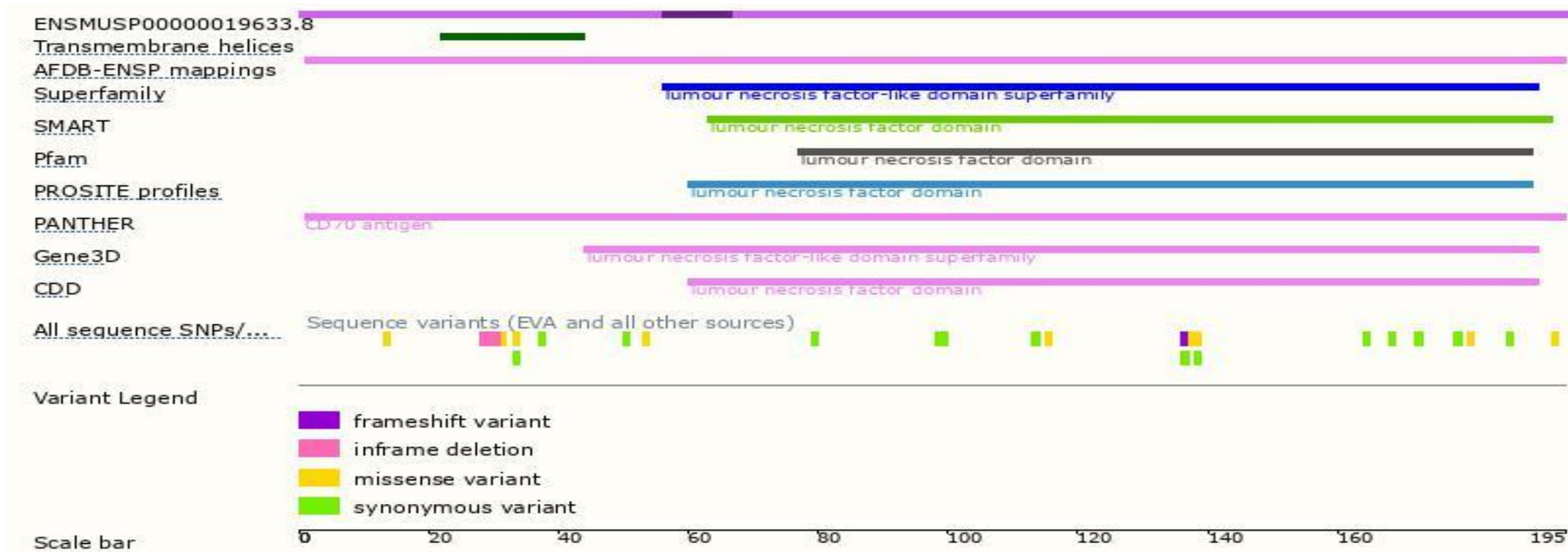

# Mouse Phenotype Information (MGI)

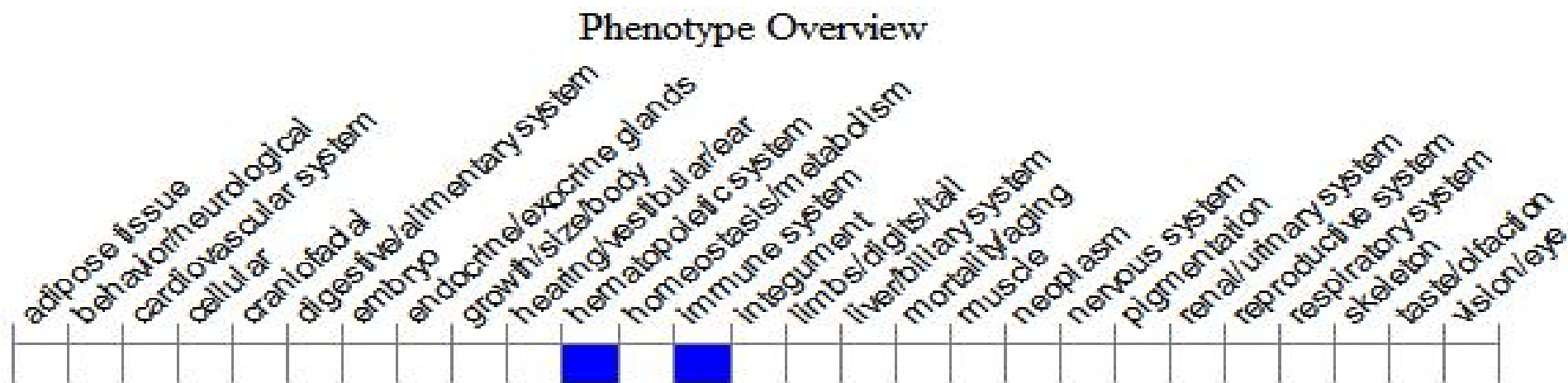

- Expansion of CD8+ cells after viral expansion is significantly less in mice with a homozygous deletion than in controls. However, the restimulation response is comparable to controls.

# Important Information

- According to the existing MGI data, expansion of CD8+ cells after viral expansion is significantly less in mice with a homozygous deletion than in controls. However, the restimulation response is comparable to controls.
- This strategy designates exon 1-2 as the knockout region according to the literature. The subsequent phenotype of this model may not be completely consistent with what is reported in the article.
- After this mice model is crossed with Cre mice, if there is a frame-shifted translation start site ATG on exon 3, truncated proteins may be translated, and whether these truncated proteins retain function is unknown.
- *Cd70* is located on Chr17. If the knockout mice are crossed with other mouse strains to obtain double homozygous mutant offspring, please avoid the situation that the second gene is on the same chromosome.
- This Strategy is designed based on genetic information in existing databases. Due to the complexity of biological processes, all risk of loxp insertion on gene transcription, RNA splicing and protein translation cannot be predicted at the existing technology level.

# Reference

Munitic I, et al., CD70 deficiency impairs effector CD8 T cell generation and viral clearance but is dispensable for the recall response to lymphocytic choriomeningitis virus. *J Immunol.* 2013 Feb 1;190(3):1169-79

A

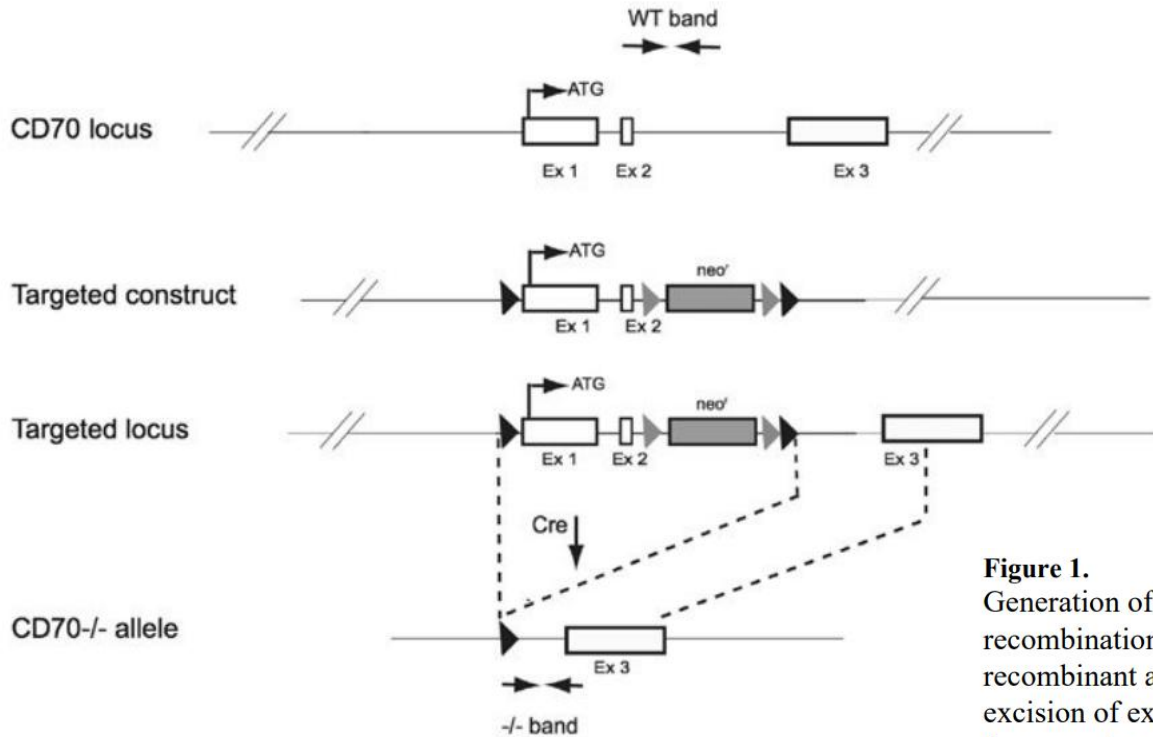

B

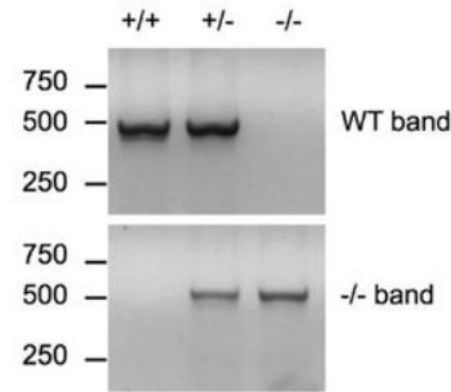

C

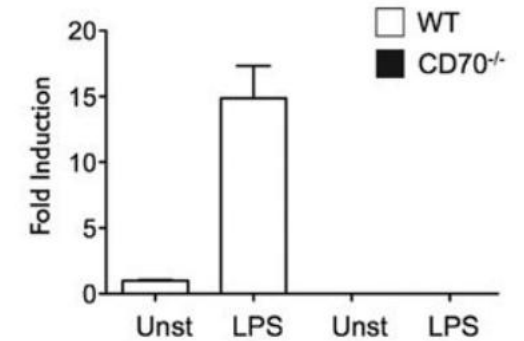

**Figure 1.**

Generation of CD70-deficient mice. (A) To generate CD70<sup>-/-</sup> mice, homologous recombination was used to insert a targeting construct into the endogenous CD70 locus. The recombinant allele contained two LoxP sites flanking exons 1 and 2. Upon Cre-mediated excision of exons 1 and 2, a CD70-deleted allele was obtained. Neo Cassette, PCR primers for screening, and loxP and FRT recombination sites are indicated in the inserted legend. Note that the map is not drawn to scale. (B) CD70<sup>-/-</sup> mice were distinguished from WT littermates by two PCR reactions, one amplifying the WT band (top panel), the other amplifying the CD70-deleted allele (bottom panel). The respective primer binding sites are shown schematically in A. (C) BMDC from WT or CD70<sup>-/-</sup> mice were stimulated with LPS for 6 hr and CD70 expression was detected by qRT-PCR. Data are shown as fold induction over unstimulated WT BMDC (fold induction = 1). Mean ± SEM for three independent experiments is shown. (D) Splenocytes from WT or CD70<sup>-/-</sup> mice were stimulated with