

# *Cd93* Cas9-CKO Strategy

<b>Designer:</b>	<b>Huan Wang</b>
<b>Reviewer:</b>	<b>Huan Fan</b>
<b>Design Date:</b>	<b>2020-5-26</b>

# Project Overview

**Project Name**

*Cd93*

**Project type**

**Cas9-CKO**

**Strain background**

**C57BL/6JGpt**

# Conditional Knockout strategy

This model will use CRISPR/Cas9 technology to edit the *Cd93* gene. The schematic diagram is as follows:

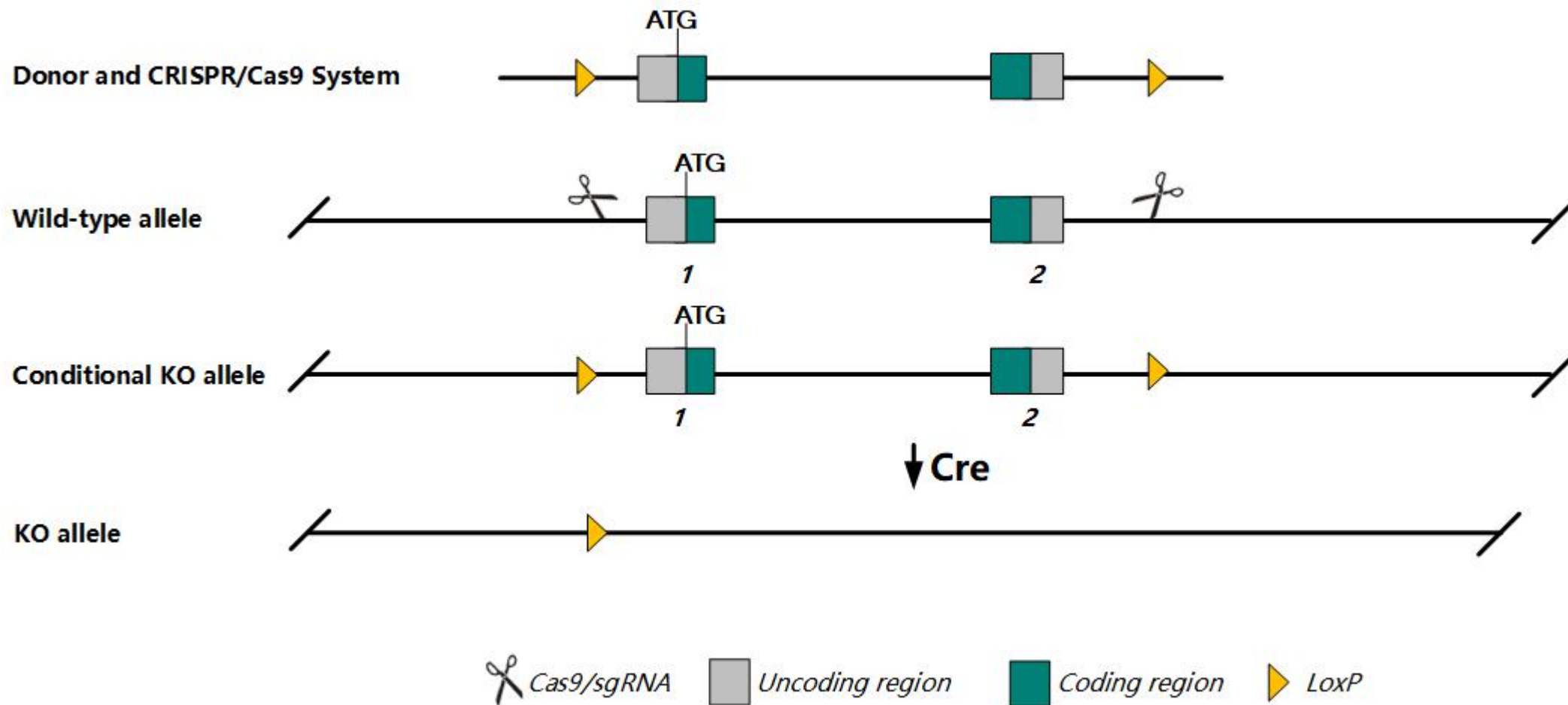

# Technical routes

- The *Cd93* gene has 1 transcript. According to the structure of *Cd93* gene, exon1-exon2 of *Cd93-201* (ENSMUST00000099269.3) transcript is recommended as the knockout region. The region contains all of the coding sequence. Knock out the region will result in disruption of protein function.
- In this project we use CRISPR/Cas9 technology to modify *Cd93* gene. The brief process is as follows: CRISPR/Cas9 system and Donor were microinjected into the fertilized eggs of C57BL/6JGpt mice. Fertilized eggs were transplanted to obtain positive F0 mice which were confirmed by PCR and sequencing. A stable F1 generation mouse model was obtained by mating positive F0 generation mice with C57BL/6JGpt mice.
- The flox mice will be knocked out after mating with mice expressing Cre recombinase, resulting in the loss of function of the target gene in specific tissues and cell types.

- According to the existing MGI data, homozygous null mutants have a defect in clearance of apoptotic cells.
- The *Cd93* gene is located on the Chr2. If the knockout mice are crossed with other mice strains to obtain double gene positive homozygous mouse offspring, please avoid the two genes on the same chromosome.
- This strategy is designed based on genetic information in existing databases. Due to the complexity of biological processes, all risk of loxp insertion on gene transcription, RNA splicing and protein translation cannot be predicted at existing technological level.

# Gene information (NCBI)

## Cd93 CD93 antigen [Mus musculus (house mouse)]

Gene ID: 17064, updated on 13-Mar-2020

### Summary



<b>Official Symbol</b>	Cd93 provided by <a href="#">MGI</a>
<b>Official Full Name</b>	CD93 antigen provided by <a href="#">MGI</a>
<b>Primary source</b>	<a href="#">MGI:MGI:106664</a>
<b>See related</b>	<a href="#">Ensembl:ENSMUSG00000027435</a>
<b>Gene type</b>	protein coding
<b>RefSeq status</b>	PROVISIONAL
<b>Organism</b>	<a href="#">Mus musculus</a>
<b>Lineage</b>	Eukaryota; Metazoa; Chordata; Craniata; Vertebrata; Euteleostomi; Mammalia; Eutheria; Euarchontoglires; Glires; Rodentia; Myomorpha; Muroidea; Muridae; Murinae; Mus; Mus
<b>Also known as</b>	6030404G09Rik, AA145088, AA4.1, AW555904, C1qr1, C1qrp, Ly68
<b>Expression</b>	Broad expression in lung adult (RPKM 38.3), subcutaneous fat pad adult (RPKM 17.9) and 15 other tissues <a href="#">See more</a>
<b>Orthologs</b>	<a href="#">human</a> <a href="#">all</a>

# Transcript information (Ensembl)

The gene has 1 transcript, and the transcript is shown below:

Name	Transcript ID	bp	Protein	Biotype	CCDS	UniProt	Flags
<b>Cd93-201</b>	<a href="#">ENSMUST00000099269.3</a>	6677	<a href="#">644aa</a>	Protein coding	<a href="#">CCDS16839</a>	<a href="#">O89103</a>	TSL:1 GENCODE basic APPRIS P1

The strategy is based on the design of *Cd93-201* transcript, the transcription is shown below:



# Genomic location distribution

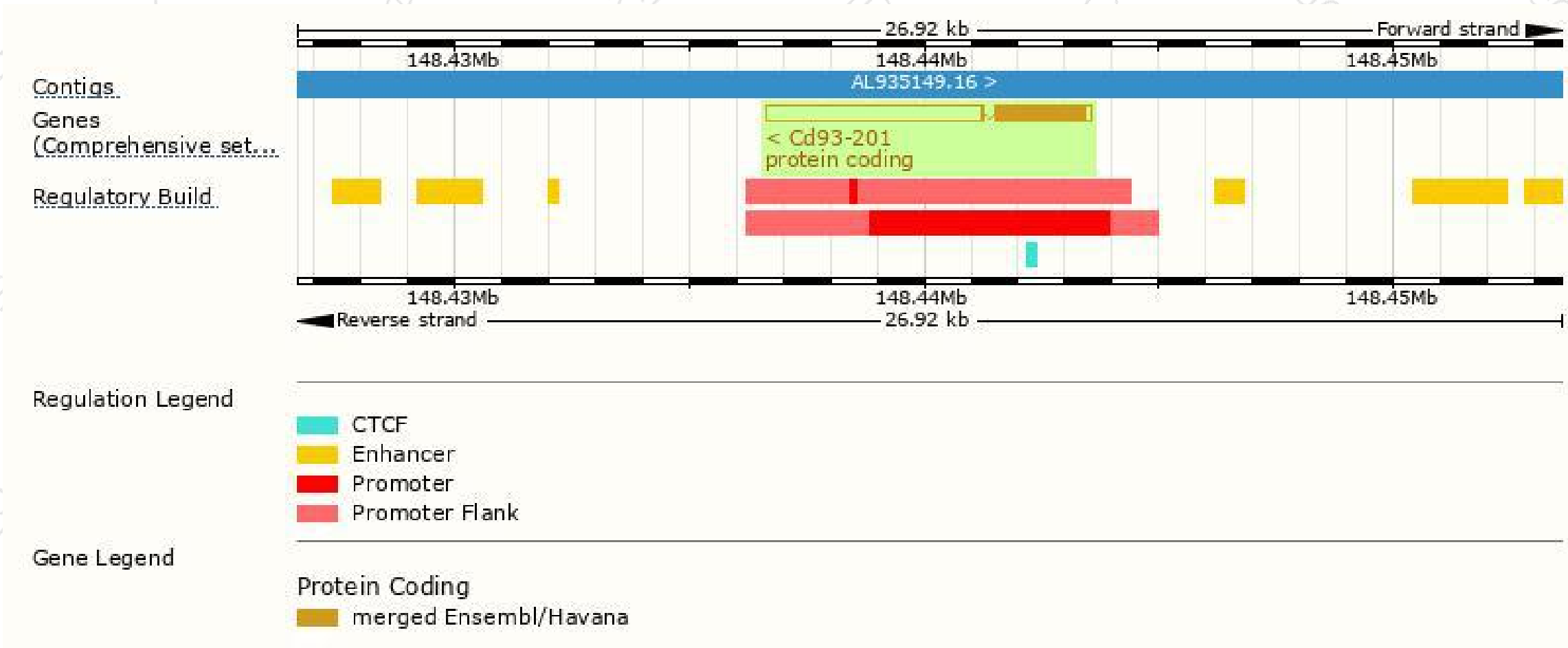

# Protein domain

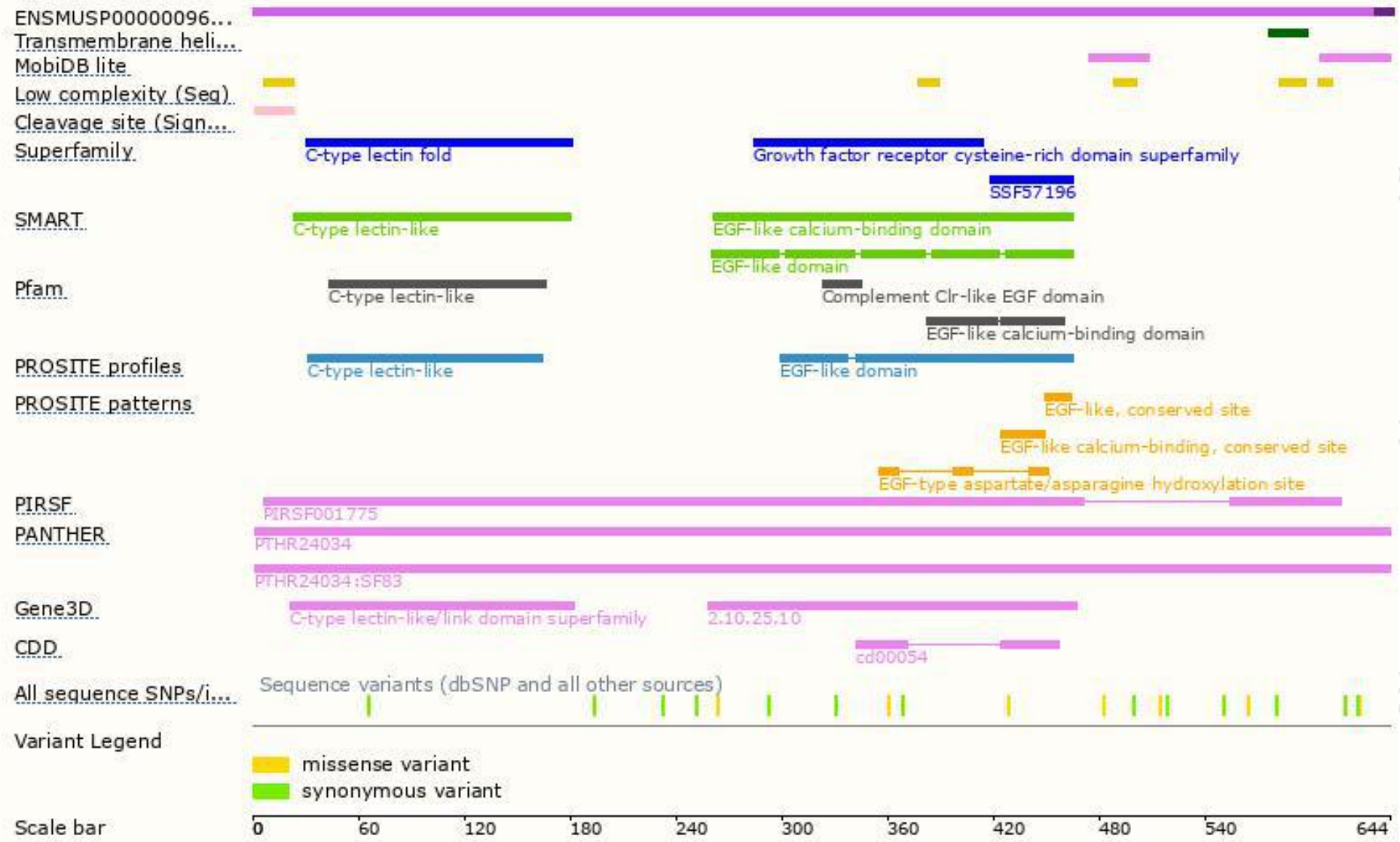

# Mouse phenotype description(MGI)

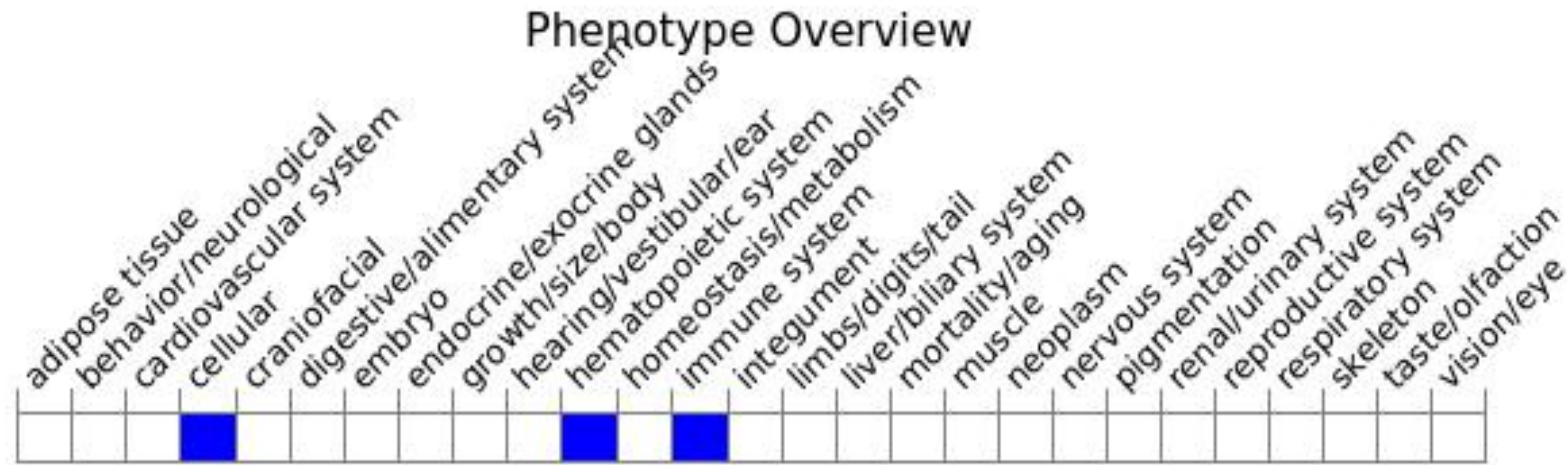

*Phenotypes affected by the gene are marked in blue. Data quoted from MGI database(<http://www.informatics.jax.org/>).*

According to the existing MGI data, homozygous null mutants have a defect in clearance of apoptotic cells.