

Genotyping Report

Strain ID	T044234	Strain Type	KO(Cas9)	Genetic Background	C57BL/6JGpt
Designer	Binjie Jiao	Gene Name	Zfp318		

1. Strategy of Genotyping

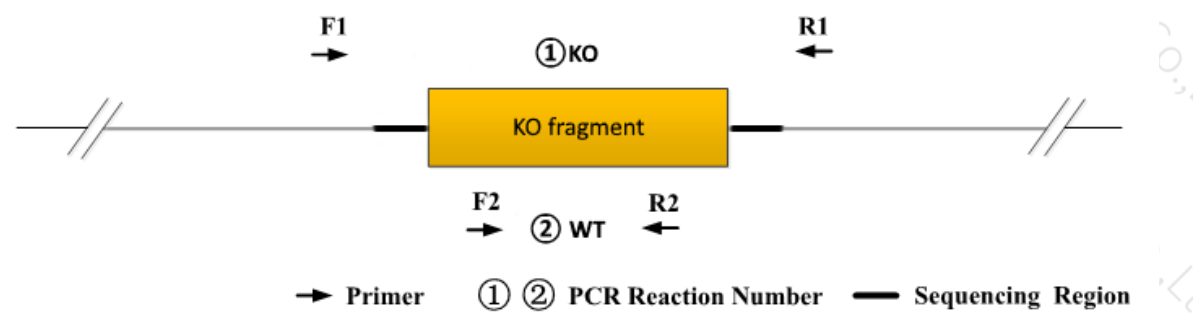

Wild type: ①PCR reaction obtains a single WT band; ②PCR reaction obtains a single WT band.
Heterozygote: ①PCR reaction obtains a WT band and a KO band; ②PCR reaction obtains a WT band.
Homozygote ①PCR reaction obtains a single KO band; ② PCR reaction without product.
Note:1)The sizes of WT and Targeted band are shown below.
2) If the WT band is too large, it may not be possible to obtain a WT band.

2. Primer Information

PCR No.	Primer No.	Primer Name	Sequence	Band Size
PCR①	F1	JS37861-KO-tF1	GGTTCAGCTCACATGTTGGATTCTC	WT:3541bp KO:615bp
	R1	JS37861-KO-tR1	AAGGAAGGAAGAGACTCACACCCT	
PCR②	F2	JS37861-wt-tF1	GGAGAACATTTTGGGCATAGAG	WT:348bp KO:0bp
	R2	JS37861-wt-tR1	GTGTTCTATCTTCCACTGGACACAG	

3. Gel Image

tgtactcactccagctccagttctcgtcc---2926bp---aggcagataggcacagctgggctggaat

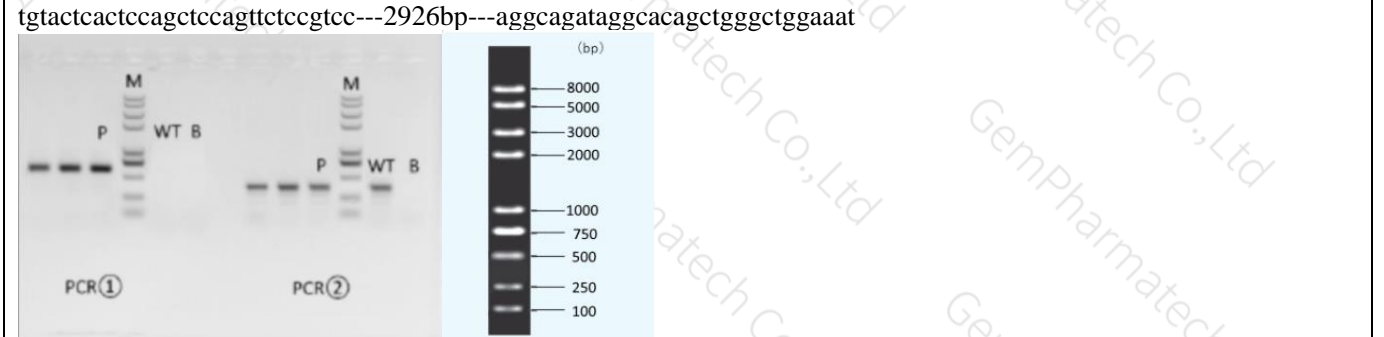

Note: P: Heterozygous samples; WT: Wildtype control; B: Blank control (ddH₂O); M: DNA Ladder
① Control (WT) : It is an important reference mark for whether the PCR reaction is successful and whether the product band position and size meet the theoretical requirements.

② Control (B) : PCR amplification was performed without template in the PCR reagent to monitor whether the reagent was contaminated.

4. PCR Condition

(Generally recommend to use Vazyme P222; If the sequences contain special structures such as GC% \geq 60% or GC% \leq 40%, recommend to use Vazyme P515.)

PCR Reaction Component			
Seg.	Reaction Component		Volume (μ l)
1	2 \times Rapid Taq Master Mix(Vazyme P222) or 2 \times Phanta Max Master Mix (Vazyme P515)		12.5
2	ddH ₂ O		9.5
3	Primer A(10pmol/ μ l)		1
4	Primer B(10pmol/ μ l)		1
5	Template(20~80ng/ μ l)		1
PCR program I (priority selection)			
Seg.	Temp.	Time	Cycle
1	95°C	5min	
2	98°C	30s	20 \times
3	65°C*(-0.5°C/cycle)	30s	
4	72°C	45s*	
5	98°C	30s	15 \times
6	55°C*	30s	
7	72°C	45s*	
8	72°C	5min	
9	10°C	hold	
PCR program II (the second choice)			
Seg.	Temp.	Time	Cycle
1	95°C	5min	
2	98°C	30s	35 \times
3	58°C*	30s	
4	72°C	45s*	
5	72°C	5min	
6	10°C	hold	

Note*: Annealing temperature and extension time can be determined according to the actual amplification situation and amplification enzyme efficiency.