

Genotyping Report

Strain ID	T033820	Strain Type	KO(Cas9)	Genetic Background	C57BL/6JGpt
Designer	Zifan Lin	Gene Name	Zfp513		

1. Strategy of Genotyping

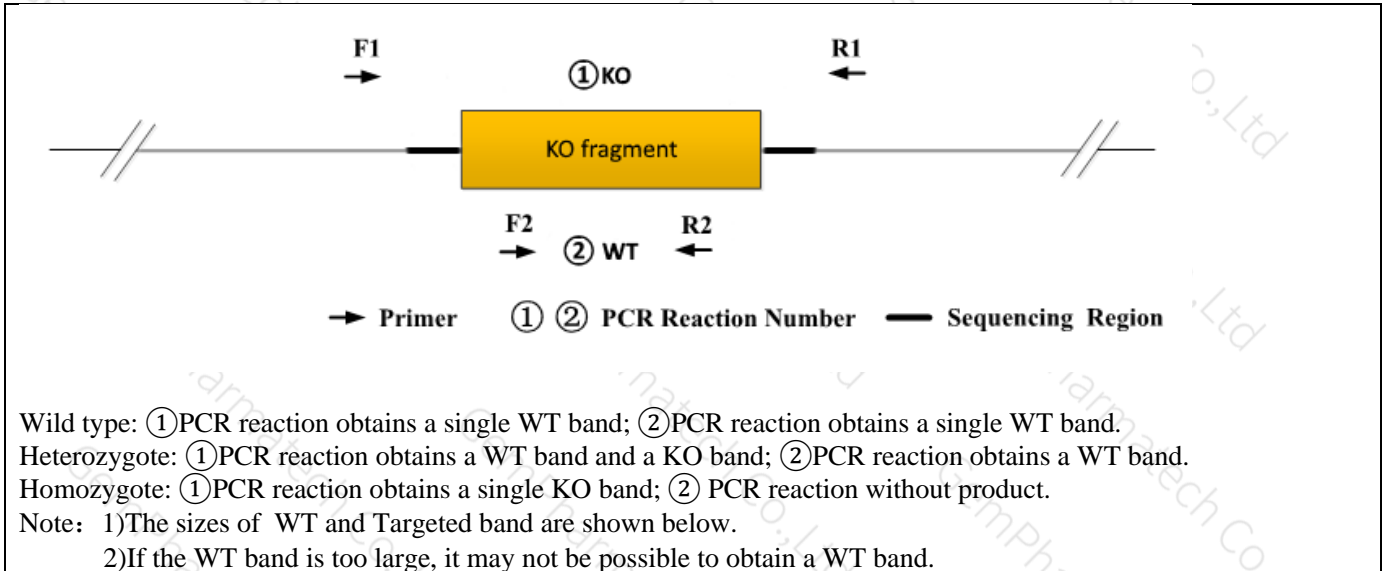

2. Primer Information

PCR No.	Primer No.	Sequence	Band Size
PCR①	T033820-F1	CATTTTGCTGAGGTGAAGTTCGG	WT: 2433bp KO: 572bp
	T033820-R1	AACAGTAAAAGGCTGGGCAGCT	
PCR②	T033820-F2	CCTTTGCCACTCACTACCCCAA	WT: 360bp KO: 0bp
	T033820-R2	TGTCACAGTGGCCTGTGGTATAG	

3. Gel Image

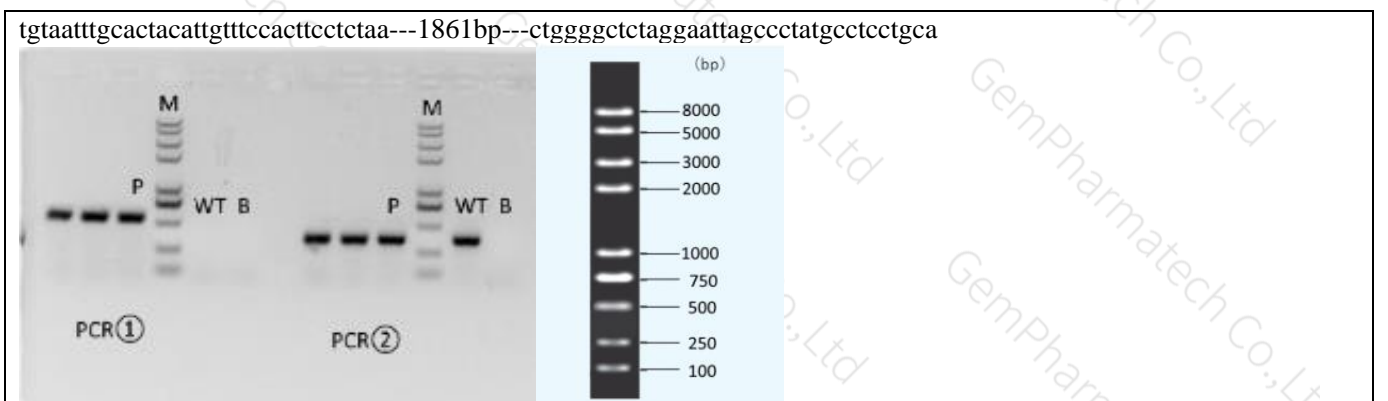

Note: P: Heterozygous samples; WT: Wildtype control; B: Blank control (ddH₂O); M: DNA Ladder

① Control (WT) : It is an important reference mark for whether the PCR reaction is successful and whether the product band position and size meet the theoretical requirements.

② Control (B) : PCR amplification was performed without template in the PCR reagent to monitor whether the reagent was contaminated.

4. PCR Condition

(Generally recommend to use Vazyme P222; If the sequences contain special structures such as GC% ≥ 60% or GC% ≤ 40%, recommend to use Vazyme P515.)

PCR Reaction Component			
Seg.	reaction component		Volume (μl)
1	2 × Rapid Taq Master Mix (Vazyme P222)		12.5
2	ddH ₂ O		9.5
3	Primer A(10pmol/μl)		1
4	Primer B(10pmol/μl)		1
5	Template(≈100ng/μl)		1
PCR program ① priority selection			
Seg.	Temp.	Time	Cycle
1	95°C	5min	
2	98°C	30s	20×
3	65°C* (-0.5°C/cycle)	30s	
4	72°C	45s*	
5	98°C	30s	20×
6	55°C*	30s	
7	72°C	45s*	
8	72°C	5min	
9	10°C	hold	
PCR program ② the second choice			
Seg.	Temp.	Time	Cycle
1	95°C	5min	
2	98°C	30s	35×
3	58°C*	30s	
4	72°C	45s*	
5	72°C	5min	
6	10°C	hold	

Note*: Annealing temperature and extension time can be determined according to the actual amplification situation and amplification enzyme efficiency.

