

## Genotyping Report

Strain ID	T015690	Strain Type	KO(Cas9)	Genetic Background	C57BL/6JGpt
Designer	Zifan Lin	Gene Name	<i>Hmmr</i>		

### 1. Strategy of Genotyping

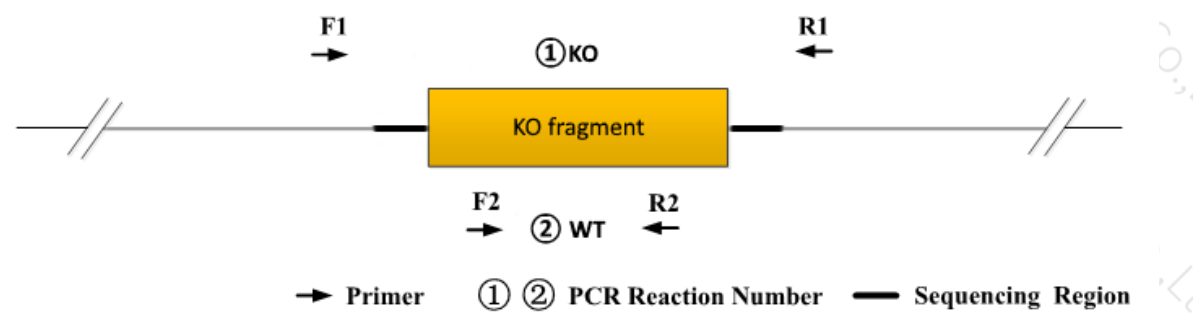

Wild type: ①PCR reaction obtains a single WT band; ②PCR reaction obtains a single WT band.  
Heterozygote: ①PCR reaction obtains a WT band and a KO band; ②PCR reaction obtains a WT band.  
Homozygote ①PCR reaction obtains a single KO band; ② PCR reaction without product.  
Note:1)The sizes of WT and Targeted band are shown below.  
2) If the WT band is too large, it may not be possible to obtain a WT band.

### 2. Primer Information

PCR No.	Primer No.	Sequence	Band Size
PCR①	T015690-F1	CTGTAGGTTGTGCTCCATCTCCG	WT: 7002bp KO: 583bp
	T015690-R1	TGAGGTCGAGGCCAGTTTGGTT	
PCR②	T015690-F2	GCTGGTGCTGGCTGATTGTTATG	WT:353bp KO:0bp
	T015690-R2	AGGAAATGCCATGACCAGAAGC	

### 3. Gel Image

actttgttatcctttctatcagaatgtag---6419bp---tggccgcttagactgttataaaataaacca

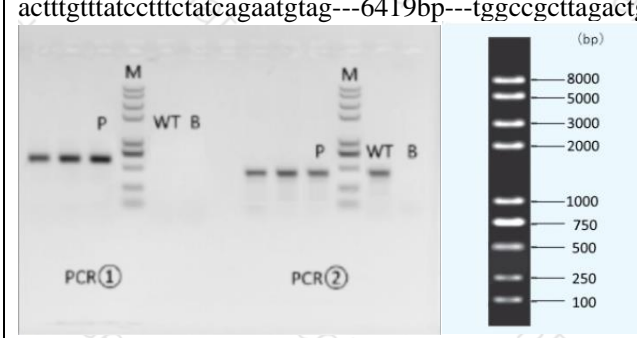

Note: P: Heterozygous samples; WT: Wildtype control; B: Blank control (ddH<sub>2</sub>O); M: DNA Ladder  
① Control (WT) : It is an important reference mark for whether the PCR reaction is successful and whether the product band position and size meet the theoretical requirements.  
② Control (B) : PCR amplification was performed without template in the PCR reagent to monitor whether the

reagent was contaminated.

#### 4. PCR Condition

(Generally recommend to use Vazyme P222; If the sequences contain special structures such as GC%  $\geq$  60% or GC%  $\leq$  40%, recommend to use Vazyme P515.)

PCR Reaction Component			
Seg.	Reaction Component		Volume ( $\mu$ l)
1	2 $\times$ Rapid Taq Master Mix(Vazyme P222) or 2 $\times$ Phanta Max Master Mix (Vazyme P515)		12.5
2	ddH <sub>2</sub> O		9.5
3	Primer A(10pmol/ $\mu$ l)		1
4	Primer B(10pmol/ $\mu$ l)		1
5	Template(20~80ng/ $\mu$ l)		1
PCR program I (priority selection)			
Seg.	Temp.	Time	Cycle
1	95°C	5min	20 $\times$
2	98°C	30s	
3	65°C*(-0.5°C/cycle)	30s	
4	72°C	45s*	
5	98°C	30s	15 $\times$
6	55°C*	30s	
7	72°C	45s*	
8	72°C	5min	
9	10°C	hold	
PCR program II (the second choice)			
Seg.	Temp.	Time	Cycle
1	95°C	5min	35 $\times$
2	98°C	30s	
3	58°C*	30s	
4	72°C	45s*	
5	72°C	5min	
6	10°C	hold	

Note\*: Annealing temperature and extension time can be determined according to the actual amplification situation and amplification enzyme efficiency.