

Genotyping Report

Strain ID	T014184	Strain Type	KO(Cas9)	Genetic Background	C57BL/6JGpt
Designer	Zifan Lin	Gene Name	<i>Baz2b</i>		

1. Strategy of Genotyping

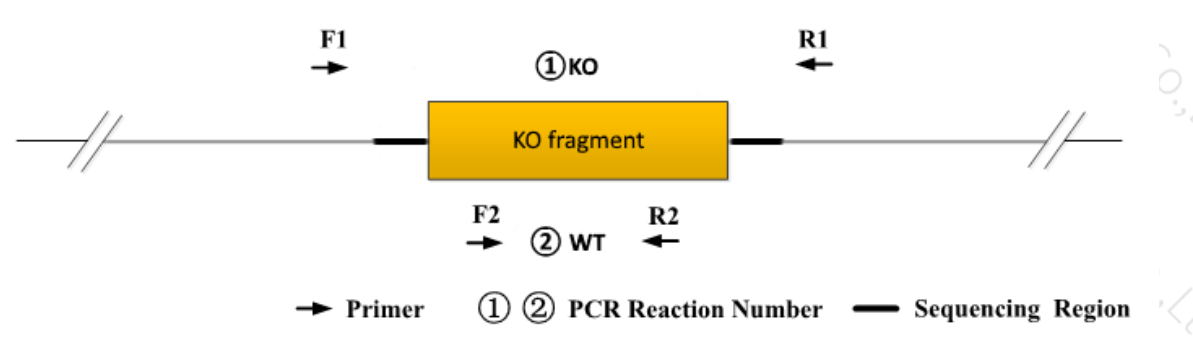

Wild type: ①PCR reaction obtains a single WT band; ②PCR reaction obtains a single WT band.
Heterozygote: ①PCR reaction obtains a WT band and a KO band; ②PCR reaction obtains a WT band.
Homozygote: ①PCR reaction obtains a single KO band; ② PCR reaction without product.
Note: 1)The sizes of WT and Targeted band are shown below.
2) If the WT band is too large, it may not be possible to obtain a WT band.

2. Primer Information

PCR No.	Primer No.	Primer Name	Sequence	Band Size
PCR①	F1	JS04650-Baz2b-5wt-tF2	CTAGACAGTGGTTGAGTGACAGGAG	WT:81403bp KO:386bp
	R1	JS04650-Baz2b-3wt-tR2	GATAAGAATGAGCTTGCCAGTGC	
PCR②	F2	JS14650-Baz2b-wt-tF2	GCACTCATGTTCTGGCTGACTTC	WT:433bp KO:0bp
	R2	JS14650-Baz2b-wt-tR2	TCTGTATGCACGCTGGCTAAAC	

3. Gel Image

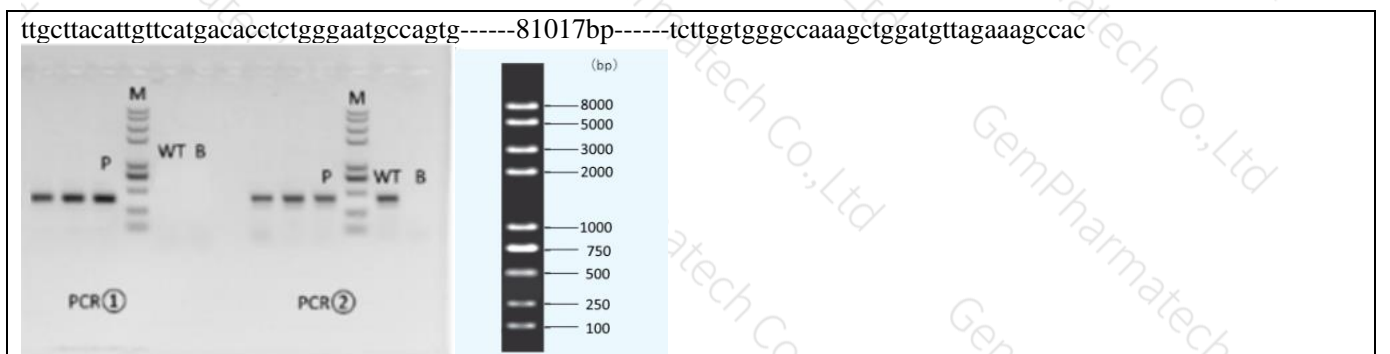

Note: P: Heterozygous samples; WT: Wildtype control; B: Blank control (ddH₂O); M: DNA Ladder

① Control (WT) : It is an important reference mark for whether the PCR reaction is successful and whether the

product band position and size meet the theoretical requirements.

② Control (B) : PCR amplification was performed without template in the PCR reagent to monitor whether the reagent was contaminated.

4. PCR Condition

(Generally recommend to use Vazyme P222; If the sequences contain special structures such as GC% ≥ 60% or GC% ≤ 40%, recommend to use Vazyme P515.)

PCR Reaction Component

Seg.	reaction component	Volume (μl)
1	2 × Rapid Taq Master Mix (Vazyme P222)	12.5
2	ddH ₂ O	9.5
3	Primer A(10pmol/μl)	1
4	Primer B(10pmol/μl)	1
5	Template(20~80ng/μl)	1

PCR program I (priority selection)

Seg.	Temp.	Time	Cycle
1	95°C	5min	
2	98°C	30s	20×
3	65°C* (-0.5°C/cycle)	30s	
4	72°C	45s*	
5	98°C	30s	15×
6	55°C*	30s	
7	72°C	45s*	
8	72°C	5min	
9	10°C	hold	

PCR program II (the second choice)

Seg.	Temp.	Time	Cycle
1	95°C	5min	
2	98°C	30s	35×
3	58°C*	30s	
4	72°C	45s*	
5	72°C	5min	
6	10°C	hold	

Note*: Annealing temperature and extension time can be determined according to the actual amplification situation and amplification enzyme efficiency.