

Il10ra Cas9-CKO Strategy

Designer:

Baocheng Zhuang

Reviewer:

Yang Zeng

Design Date:

2018-6-26

Project Overview

Project Name

Il10ra

Project type

Cas9-CKO

Strain background

C57BL/6JGpt

Conditional Knockout strategy

This model will use CRISPR/Cas9 technology to edit the *Il10ra* gene. The schematic diagram is as follows:

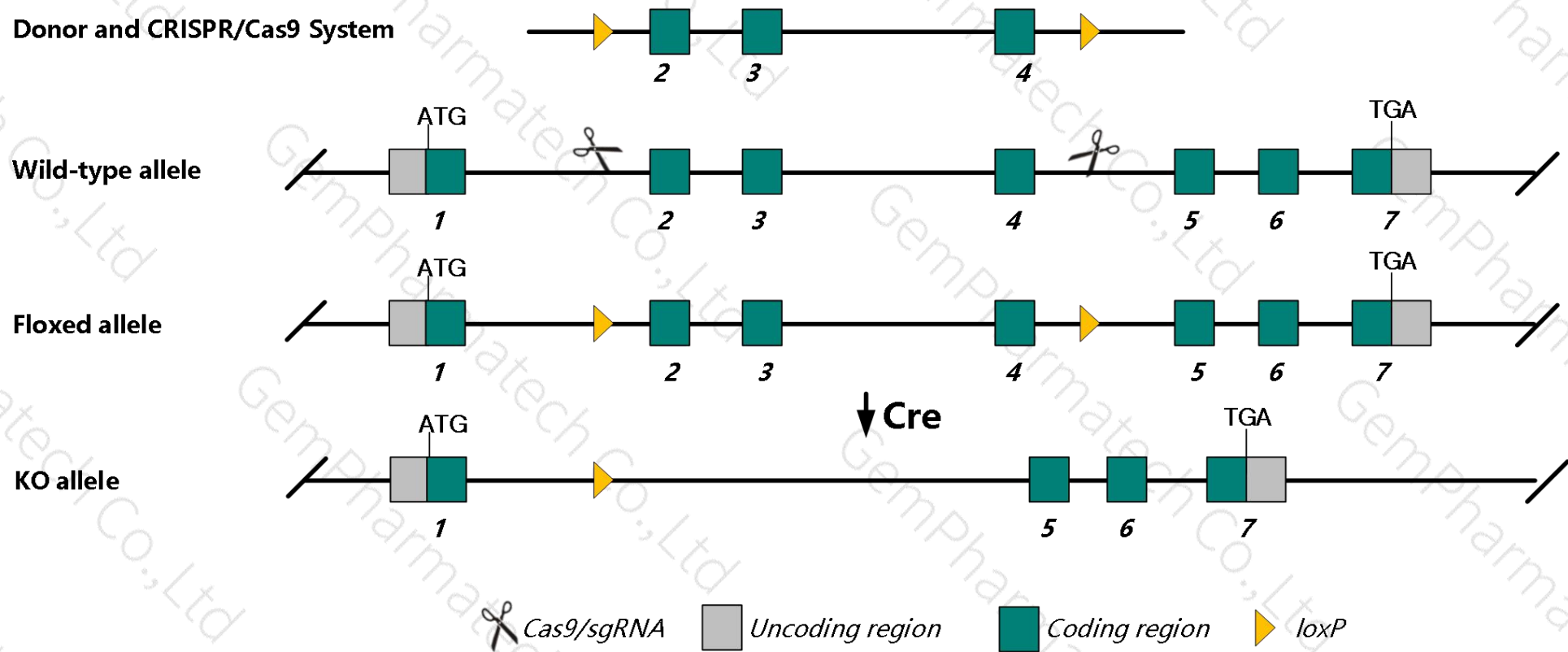

Technical routes

- The *Il10ra* gene has 3 transcripts. According to the structure of *Il10ra* gene, exon2-exon4 of *Il10ra*-201 (ENSMUST00000034594.15) transcript is recommended as the knockout region. The region contains 476bp coding sequence. Knock out the region will result in disruption of protein function.
- In this project we use CRISPR/Cas9 technology to modify *Il10ra* gene. The brief process is as follows: gRNA was transcribed in vitro, donor was constructed. Cas9, gRNA and Donor were microinjected into the fertilized eggs of C57BL/6JGpt mice. Fertilized eggs were transplanted to obtain positive F0 mice which were confirmed by PCR and sequencing. A stable F1 generation mouse model was obtained by mating positive F0 generation mice with C57BL/6JGpt mice.
- The flox mice will be knocked out after mating with mice expressing Cre recombinase, resulting in the loss of function of the target gene in specific tissues and cell types.

- According to the existing MGI data, Mice homozygous for an ENU-generated null allele suffer from a severe inflammatory bowel syndrome. Mice heterozygote for an NZW variant allele have high sera levels of anti-chromatin antibodies. Mice homozygous for a knock-out allele exhibit increased susceptibility to induced colitis.
- The KO region overlaps with the *Mir7086* gene. Knockout the region may affect the function of *Mir7086* gene.
- The *Il10ra* gene is located on the Chr9. If the knockout mice are crossed with other mice strains to obtain double gene positive homozygous mouse offspring, please avoid the two genes on the same chromosome.
- This Strategy is designed based on genetic information in existing databases. Due to the complexity of biological processes, all risk of loxp insertion on gene transcription, RNA splicing and protein translation cannot be predicted at existing technological level.

Gene information (NCBI)

Il10ra interleukin 10 receptor, alpha [*Mus musculus* (house mouse)]

Gene ID: 16154, updated on 12-Aug-2019

Summary

Official Symbol	Il10ra provided by MGI
Official Full Name	interleukin 10 receptor, alpha provided by MGI
Primary source	MGI:MGI:96538
See related	Ensembl:ENSMUSG00000032089
Gene type	protein coding
RefSeq status	VALIDATED
Organism	Mus musculus
Lineage	Eukaryota; Metazoa; Chordata; Craniata; Vertebrata; Euteleostomi; Mammalia; Eutheria; Euarchontoglires; Glires; Rodentia; Myomorpha; Muroidea; Muridae; Murinae; Mus; Mus
Also known as	Il10r; CDw210; CDw210a; IL-10R1; IL-10RA; mL-10R; AW553859
Expression	Biased expression in spleen adult (RPKM 30.8), thymus adult (RPKM 10.6) and 11 other tissues See more
Orthologs	human all

Transcript information (Ensembl)

The gene has 3 transcripts, all transcripts are shown below:

Name ▲	Transcript ID ▲	bp ▲	Protein ▲	Translation ID ▲	Biotype ▲	CCDS ▲	UniProt ▲	Flags ▲
II10ra-201	ENSMUST00000034594.15	3498	575aa	ENSMUSP00000034594.9	Protein coding	CCDS23131	Q3UDL4 Q61727	TSL:1 GENCODE basic APPRIS P3
II10ra-202	ENSMUST00000176222.1	2799	573aa	ENSMUSP00000135461.1	Protein coding	CCDS85671	H3BKN6	TSL:1 GENCODE basic APPRIS ALT2
II10ra-203	ENSMUST00000176808.1	3374	85aa	ENSMUSP00000135361.1	Nonsense mediated decay	-	H3BKE8	TSL:1

The strategy is based on the design of *II10ra-201* transcript, The transcription is shown below

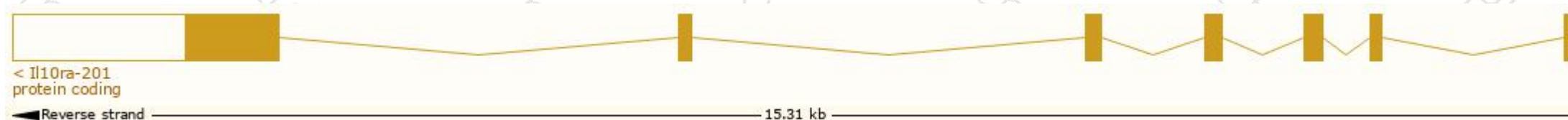

Genomic location distribution

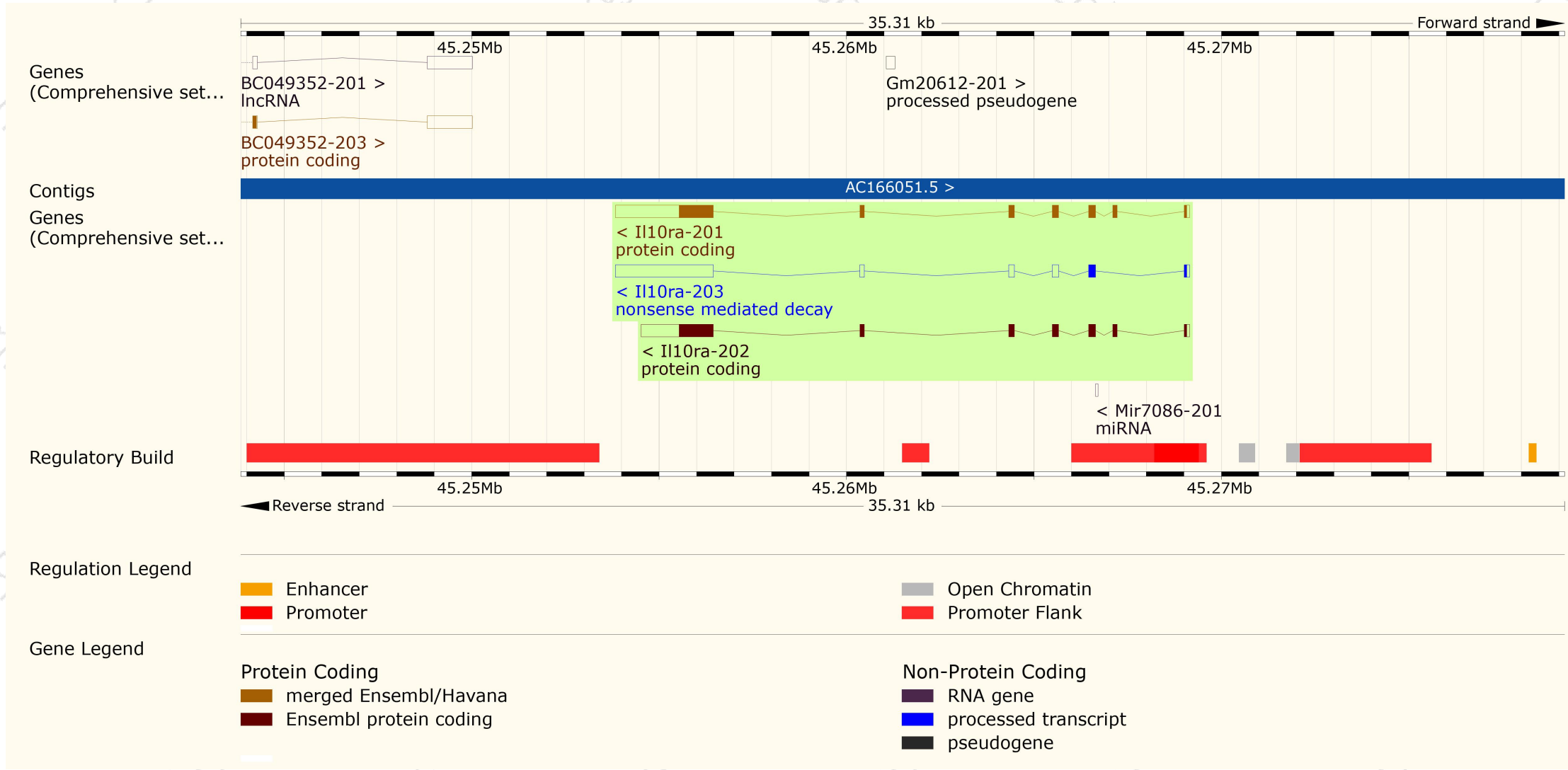

Protein domain

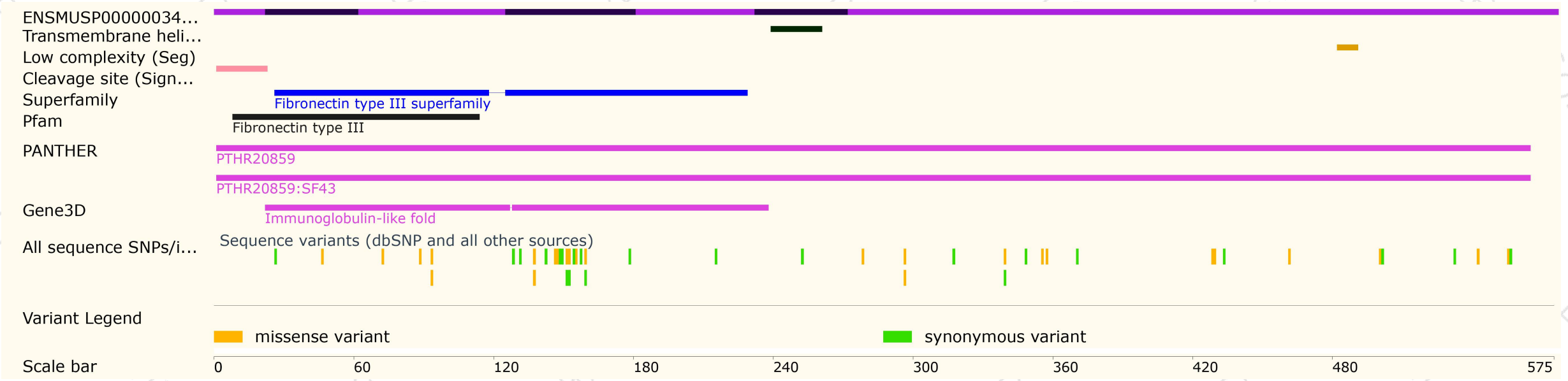

Mouse phenotype description(MGI)

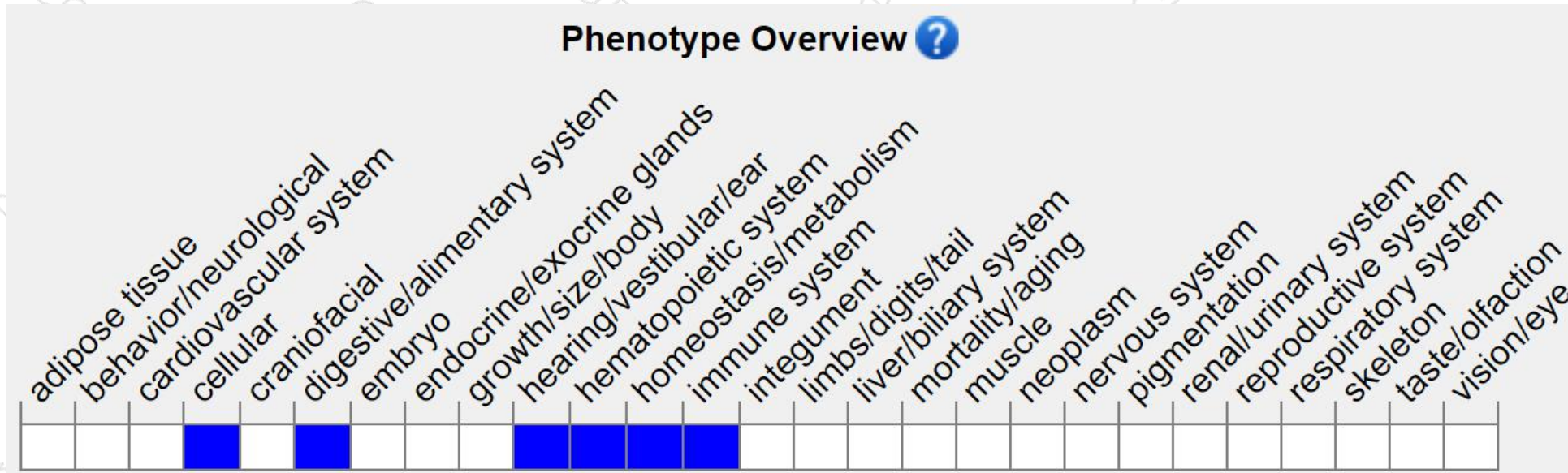

Phenotypes affected by the gene are marked in blue. Data quoted from MGI database (<http://www.informatics.jax.org/>).

According to the existing MGI data, Mice homozygous for an ENU-generated null allele suffer from a severe inflammatory bowel syndrome. Mice heterozygote for an NZW variant allele have high sera levels of anti-chromatin antibodies.

Mice homozygous for a knock-out allele exhibit increased susceptibility to induced colitis.

If you have any questions, you are welcome to inquire.

Tel: 400-9660890

